



The Swiss Revolution.

Clipping without clips, only with wire.
The new MODEL R from SwissClip.

A success story from Switzerland.



A high-tech innovation that revolutionizes your food packaging and reduces your clipping costs by 50%.

- 04 Cheaper
- 06 Faster
- 08 More flexible
- 10 Hygienic
- 12 Swiss
- 14 User-friendly
- 16 Facts, figures and data



Cheaper

You can save money without sacrificing quality.

Up to

50%

cheaper, because you simply make your own clips, instead of paying high prices.



Cleaner,
safer and
more
efficient.

The SwissClip "MODEL R" is a double-clipping machine in which practically any wire plays the main role – and not expensive ready-made clips. This is because the MODEL R produces clip closures from round wire. This means that all known plastic, fiber and collagen casings from a caliber of 30 to 140 mm can be closed cleanly and efficiently.

The main difference lies in the cost of the consumables. Wire is considerably cheaper than ready-made clips from a roll, takes up less storage space and is often significantly cheaper to import. With SwissClip you save in any case – often to the tune of more than 50% when clipping.

- The MODEL R produces the clips itself and therefore reduces clipping costs.
- Many more clips per roll compared to pre-produced flat clips.
- Smaller rolls for more clips ensure better handling and less storage space.
- Only 3 tools that can be used universally.
- Many different clip sizes can be easily produced and thus efficiently matched to the end product.
- The raw material for the wire is generally available everywhere quickly, easily and cheaply.

Faster

Your production without limits.

SwissClip technology enables production at maximum speed and is therefore more economical than conventional methods. Up to 120 portions per minute or 8,000 kg per hour – depending on the filler capacity and caliber – stand for incomparably high productivity and efficiency, as well as an exceptional ROI.

Whether for packaging sausage products, dairy products, seafood or something else – SwissClip MODEL R always offers optimum performance and unsurpassed flexibility. After all, switching from one process to another is particularly easy, fast and hygienic, making it extremely efficient in every respect.

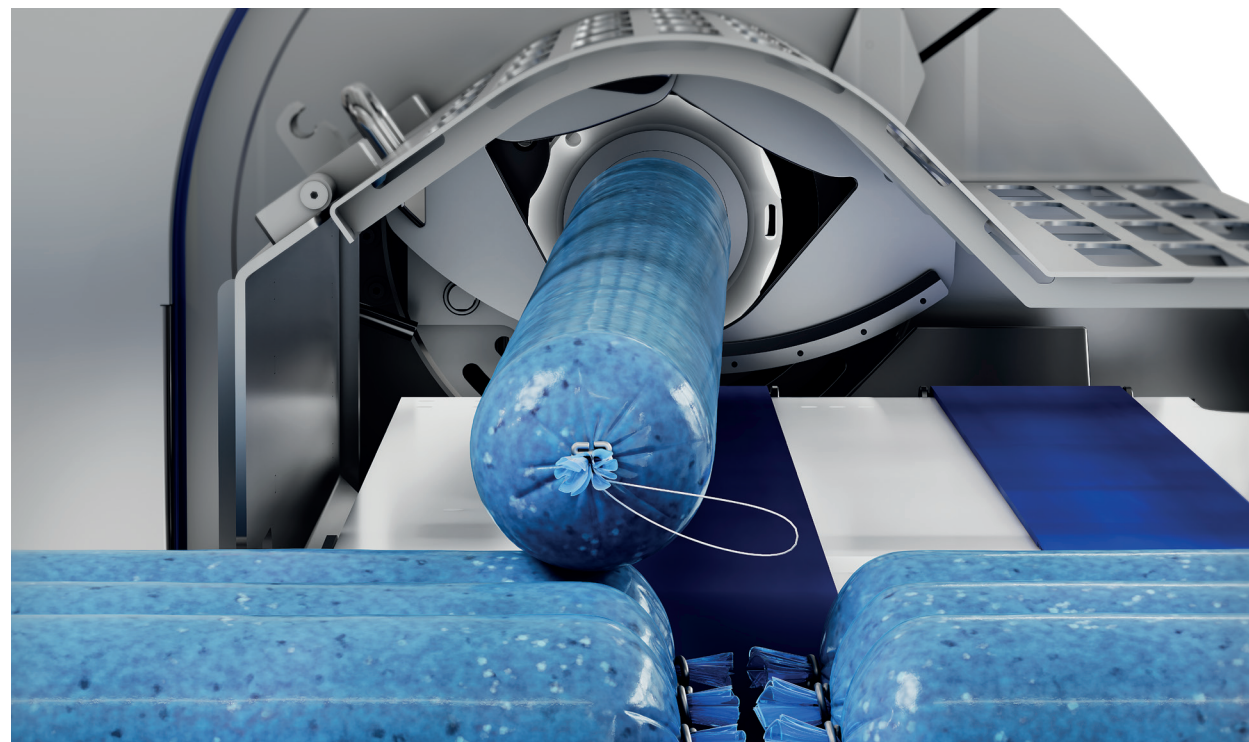

Up to

8,000 kg

per hour possible

More quantity, higher yield.





More flexible

**Does exactly
what you want
it to do.**



3

tool sizes

120

bars per minute

30–140 mm

caliber

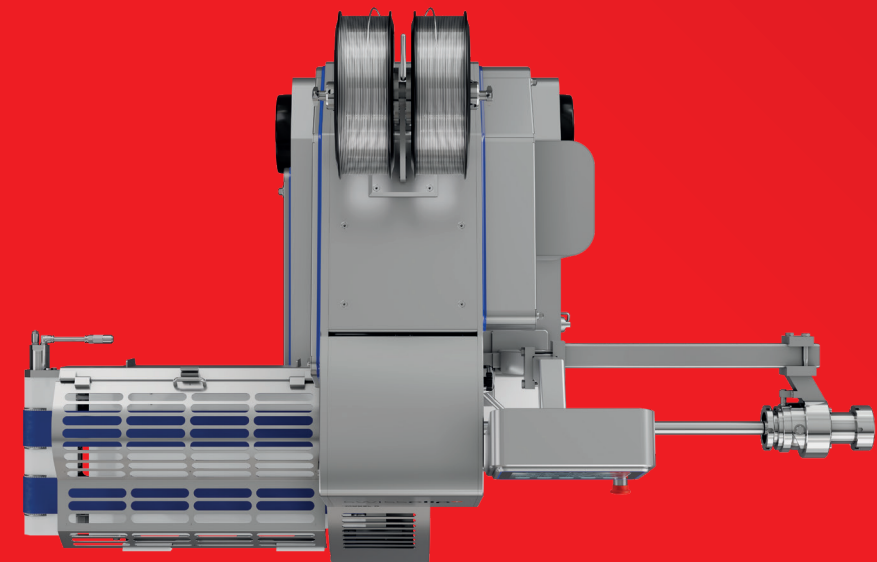

The SwissClip machines can be connected to all standard filling machines. They close the portions precisely to form individual, chain and ring sausages with/without a hanging loop and without any filling material residue in the sausage tails. This modern sealing technology can of course also be used for many applications outside the meat industry – for

example, for packaging semi-finished confectionery products, cheese, soups or non-food products.

A further advantage: The quick conversion to a different die size enables individual use and increases the flexibility of the caliber range.

More hygienic

Taste and hygiene is the best recipe.

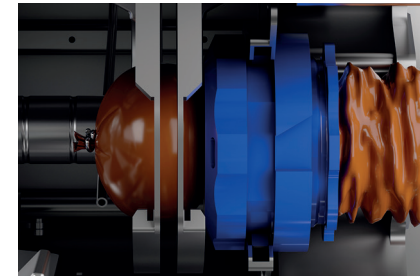

Filling

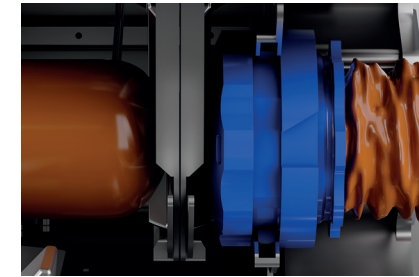

Gathering

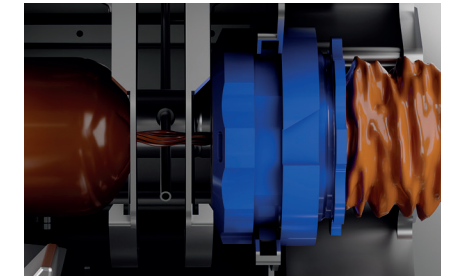

Displacing and clipping

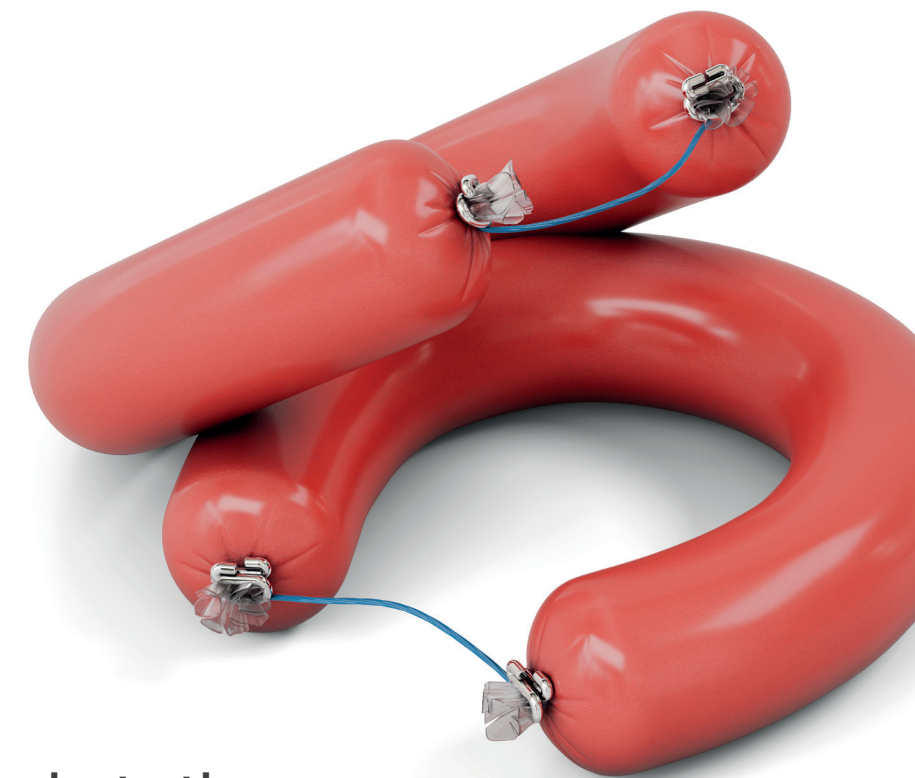

100%

safety and quality thanks to the highest hygiene standards.

Food processing is cleaner, safer and more hygienic than with conventional clipping. The three steps of gathering, displacing and clipping prevent residue in the clips.

In addition, the SwissClip double-clip machine offers maximum ease of maintenance and service. Smooth, rust-free surfaces (without screw heads) or dirt corners and horizontal surfaces inclined by 3 degrees as well as additional recesses are design elements that

allow quick and hygienic cleaning. Valves, drives and controls are hermetically sealed against water and dirt by covers.

Maintenance is therefore not only particularly easy, but also quick and – above all – efficient. This ensures maximum food safety in compliance with the strictest legal requirements as well as consistently good product quality and therefore maximum consumer confidence.

Swiss

As solid and stable in value as a Swiss watch.



Switzerland is the epitome of exceptional engineering and sustainable development in terms of machines for food production. Of course, this also applies to the SwissClip MODEL R.

The entire machine is completely stainless. The precise wire guidance and wire feed are controlled by cam disks. These design solutions give the SwissClip machines a long service life with minimal wear.

For maintenance work, the clip cam can be controlled manually via the touchscreen. The parameters for blade and tool changing as well as the cleaning position can also be called up via the touchscreen.

- Precise cam-controlled wire feed and wire guidance.
- No chain drives and springs, therefore fewer wearing parts and less soiling.
- Gentle wire removal from the reel.
- No push-back of the wire when closing the clip.
- Access through windows/openings in the machine wall for easy cleaning, simple maintenance and convenient servicing.
- Low maintenance requirements and therefore low maintenance costs.
- Extremely safe to operate.



Durable,
versatile,
safe.

User-friendly
**Compact
 and intuitive
 to operate.**



**Easy-
to-use
design.**

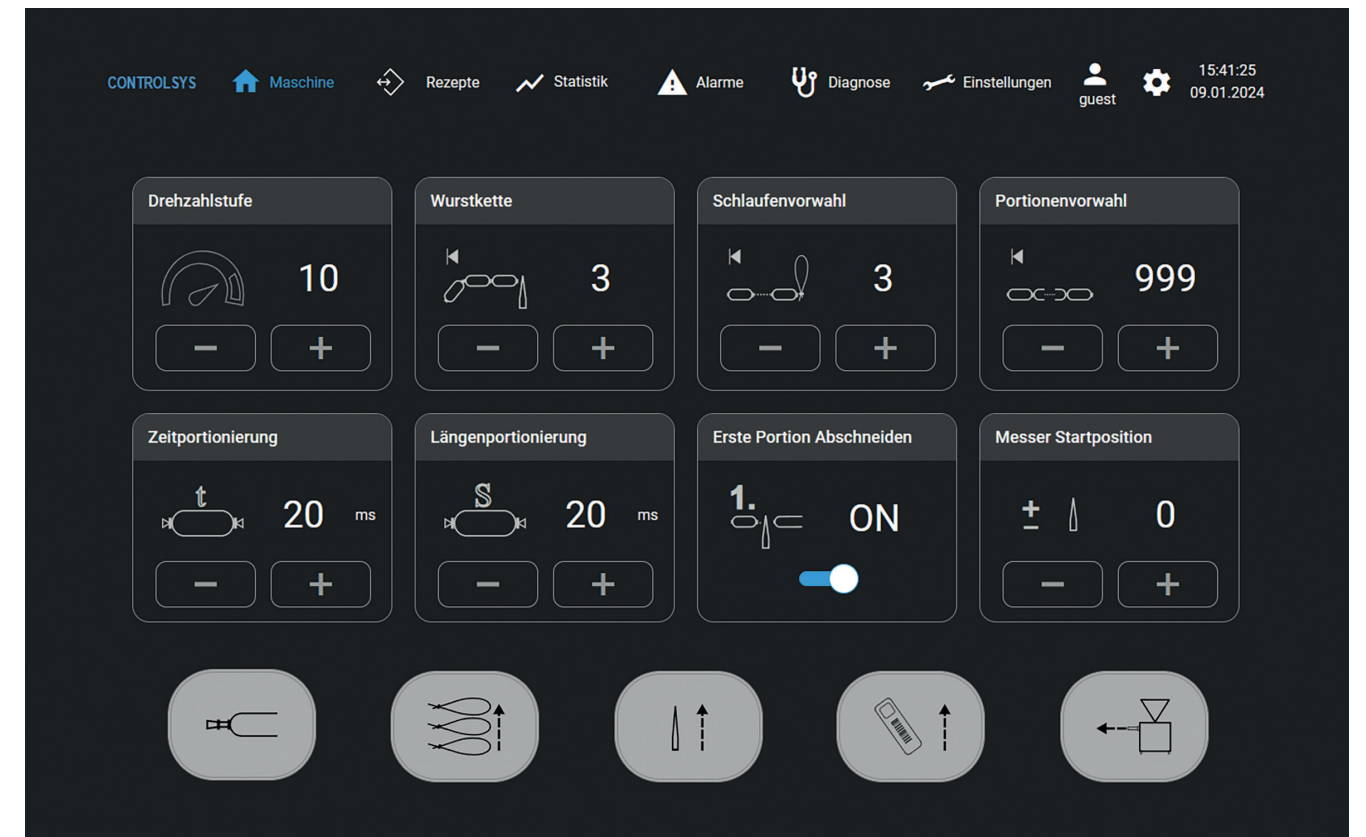

Superior ergonomics.

The SwissClip Model R is characterized by superior ergonomics and simple operation. This makes it clear that the focus during development was on the user, on the one hand, and the entrepreneur, on the other. In addition, the ergonomic design minimizes fatigue and thus maximizes efficiency.

Intuitive controls.

Intuitive operating elements and user-friendly controls ensure precise and largely effortless handling. Operation is so simple that even the training and familiarization time for staff can be reduced.

Figures, data, facts

For those who like precise information.

The SwissClip MODEL R is equipped with a maintenance-free servo drive and a PLC control system. The machine is operated via a touchscreen. This modern operating system with graphic visualization and alphanumeric full-text display in many national languages leaves nothing to be desired in terms of convenience, hygiene and efficiency.

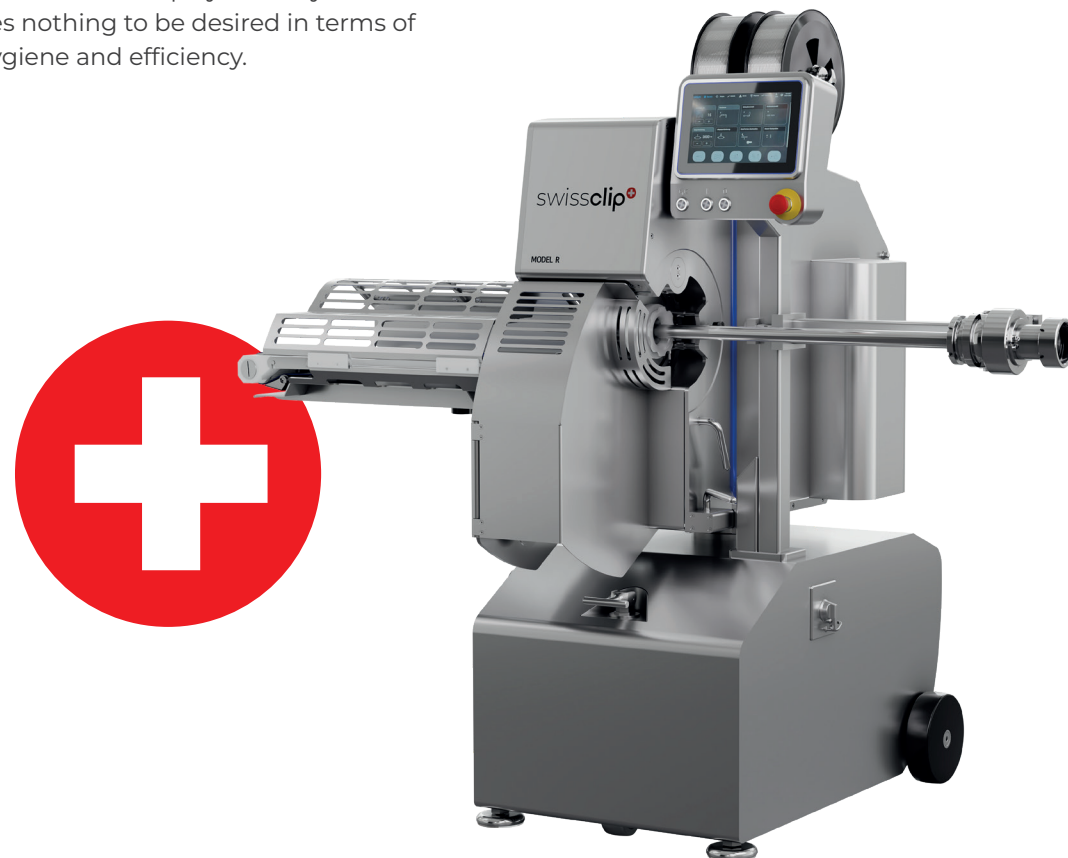

Equipment

- Automatic belt loop feeder
- Device for ring sausages
- Swivel head
- Belt outlet or chute
- Front wheel for easy maneuvering

Advantages

- Ergonomic, compact design for high operating comfort
- Blade, tool change and cleaning position can be called up via touchscreen
- Quick changeover to a different tool size
- Few conversions necessary as only 3 tool sizes
- Easy and hygienic cleaning thanks to smooth surfaces 3-degree-inclination
- 20 speed levels plus throughfeed for maximum productivity

Technical data

- **Width x height x depth without FB and filling pipe:**
783 x 1,085 x 1,684–1,848 mm
- **with FB and filling pipe:**
1,581–1,998 x 1,085 x 1,684–1,848 mm
- **Supply voltage:**
3 x 400V/50 Hz or 60 Hz
- **Connected load:**
5 kW
- **Protection class:**
IP 65 (touchscreen: IP 69K)
- **Air consumption:**
5.0 L/cycle @ 7 bar
- **Compressed air:**
6–7 bar
- **Caliber range:**
30–140 mm
- **Cycle rate:**
Up to 120 portions/min
- **3 tools:**
13 – 18 – 20
- **Aluminum processing wire:**
Ø 2.5, 2.8 or 3.0 mm
- **Sound pressure level:**
dBa 81
- **Weight:**
575 kg

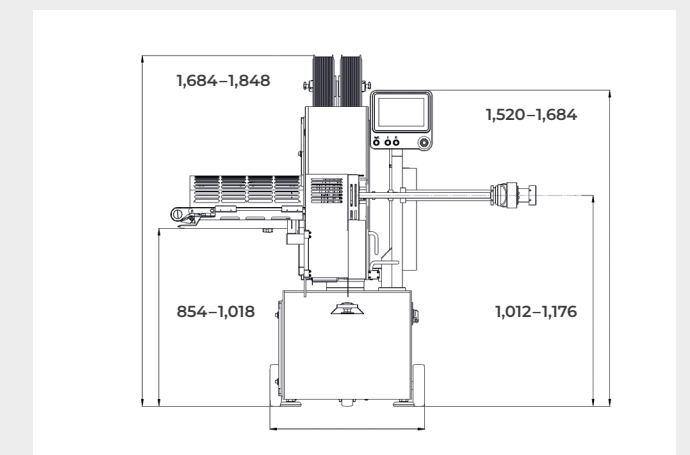
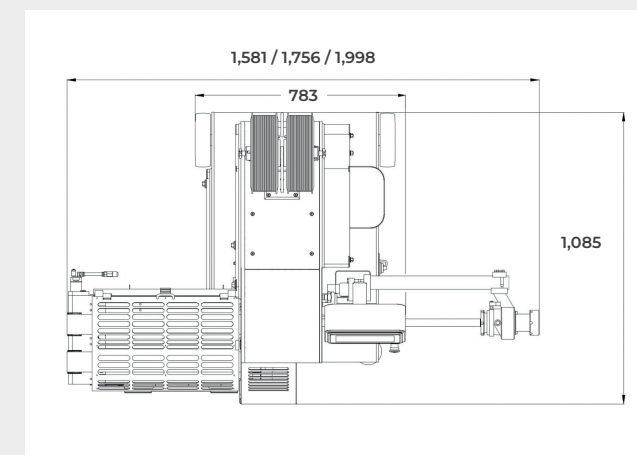

All data in mm.

Do you also
want to
revolutionize
your production
and reduce
costs?



Then write to us
or give us a call –
we will be happy to
advise you.

info@swissclip.ch
+41 79 617 75 57 or
+41 79 613 26 62



